

WORKSHOP EQUIPMENT EXPERTS



TOTALKARE
WORKSHOP EQUIPMENT EXPERTS

GET IN TOUCH



ADDRESS

Dandy Bank Road
Pensnett Trading Estate
Kingswinford
West Midlands
DY6 7TD



CALL US

Tel: 0121 585 2724
24/7 Service: 0121 585 2727
Fax: 0121 585 2725



EMAIL US

Sales: sales@totalkare.co.uk
Service: service@totalkare.co.uk
Accounts: accounts@totalkare.co.uk



WEBSITE

Visit us: www.totalkare.co.uk



TABLE OF CONTENTS

| | |
|----------------------------|----|
| Mobile column lifts..... | 4 |
| Fixed Post Lifts | 5 |
| LCV Lifts..... | 7 |
| Brake Testers | 8 |
| Inspection Equipment | 9 |
| Diagnostic Equipment..... | 10 |
| Class VII MOT Bay | 12 |
| Ancillary Equipment | 14 |
| Torque Tools..... | 18 |
| Air Conditioning | 20 |
| Oil Management | 21 |
| Service & Inspection | 22 |
| Finance Solutions | 22 |
| Training..... | 23 |



MOBILE COLUMN LIFTS

T8DC CABLE-FREE

- ◆ 7,500kg lifting capacity per column
- ◆ No interconnecting cables
- ◆ Available in 4, 6 or 8 column configuration
- ◆ Adjustable forks for different wheel sizes
- ◆ Only requires a single phase 230v power supply for charging
- ◆ Ideal for commercial vehicles, buses, coaches, skiploaders, waste & recycling vehicles, heavy haulage, light commercial and more
- ◆ CE design certification



T8AC CABLED

- ◆ 7,500kg lifting capacity per column
- ◆ Available in 4, 6 or 8 column configuration
- ◆ Adjustable forks for different wheel sizes
- ◆ Control lifting operations from any column
- ◆ Quick and easy interconnections of cables
- ◆ Inverted Hydraulic Cylinder lifting system
- ◆ Complete flexibility and manoeuvrability within the workplace

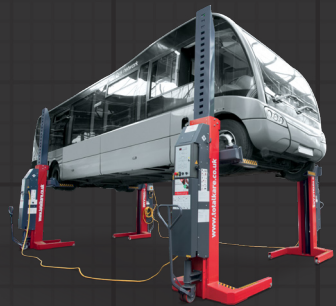

MOBILE COLUMN LIFTS



G8AC WASHBAY

- ◆ Sealed bearings & galvanised to give long term protection from water ingress
- ◆ 7,500kg lifting capacity per column
- ◆ No installation or groundwork requirements
- ◆ Adjustable forks for different wheel sizes
- ◆ Electromechanical lifting system

FIXED POST LIFTS

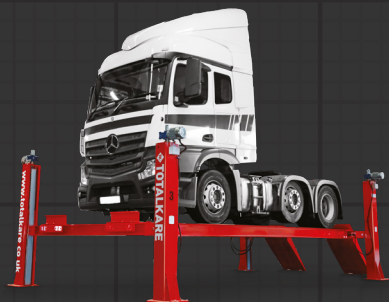

FOUR POST HEAVY DUTY

- ◆ Lifting capacities of 8,000kg - 33,000kg
- ◆ Range of platform lengths from 7m - 18m
- ◆ Drive through width of 3300mm with 700mm wide platforms
- ◆ Can be surface mounted or recessed into the floor for a flush fit
- ◆ Optional galvanisation for washbay/outside applications



FIXED POST LIFTS

Y-MECH LIFT

HEAVY DUTY

- ◆ Lifting capacities of 25,000kg - 35,000kg
- ◆ Range of platform lengths from 6m - 13m
- ◆ Can be surface mounted or recessed into the floor for a flush fit
- ◆ Floor supports are hot-dip galvanised and thus optimally protected against corrosion
- ◆ Rails are lifted vertically, thus allowing access all around the lift
- ◆ Optional galvanisation for washbay/outside applications



IN-GROUND LIFT

HEAVY DUTY

- ◆ 15,000kg capacity per piston
- ◆ Wheel-free access
- ◆ Installed in self-contained cassette built into the workshop floor
- ◆ 2, 3 or 4 piston configurations to suit all vehicle types
- ◆ Can be driven over when not in use



LCV LIFTS



FOUR POST LIGHT COMMERCIAL

- ◆ Lifting capacity from 4,000kg-6,500kg
- ◆ A range of platform lengths from 4.7-6m
- ◆ Can be surface mounted or recessed into the floor for a flush fit
- ◆ Suitable for lifting lighter weight vehicles such as long wheel base vans
- ◆ Jacking beam options available
- ◆ Lighting options available
- ◆ Site surveys upon request



TWO POST LIGHT COMMERCIAL

- ◆ A range of capacities available: 3,500kg, 4,500kg, 5,000kg, 5,500kg, 6,500kg
- ◆ Electro-hydraulic design
- ◆ Non-load bearing cables ensure even lifting and lowering
- ◆ Each column equipped with own control unit
- ◆ Lifting speed from 30-60sec dependent on model
- ◆ Baseless frame-free design



BRAKE TESTERS

MOBILE BRAKE TESTER

- ◆ DVSA-approved
- ◆ Axle load up to 20,000kg
- ◆ Tablet interface allows user to control and monitor test results directly on handheld unit
- ◆ Single or bi-directional rollers
- ◆ Connected equipment ready



IN-GROUND BRAKE TESTER

- ◆ DVSA-approved
- ◆ Install across a pit, as part of an ATF lane or as a standalone application
- ◆ Axle load up to 20,000kg
- ◆ Optional axle load simulation
- ◆ Connected-equipment ready



CLASS VII IN-GROUND BRAKE TESTER

- ◆ Maximum axle load of 6,000kg
- ◆ DVSA-approved
- ◆ GEA-approved
- ◆ Designed to suit light commercial vehicles
- ◆ Bi-directional rollers

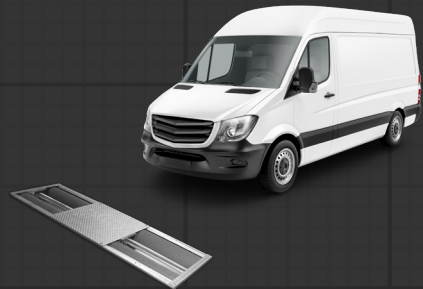

INSPECTION EQUIPMENT

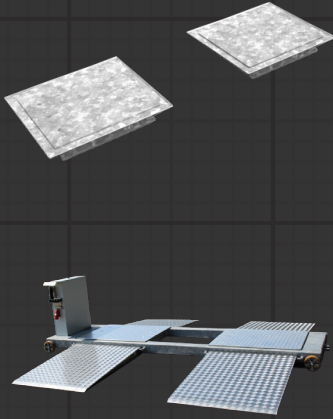

SHAKER PLATES MOBILE & IN-GROUND

- ◆ Checks steering and suspension system
- ◆ 20,000kg maximum axle load
- ◆ Plates move horizontally in 8 different directions controlled by the operator
- ◆ Remote control with keypad to control each movement
- ◆ High quality galvanised steel
- ◆ Can be supplied with an axle load system to add 8,000kg to the axle
- ◆ Plate speed: 36 mm/s

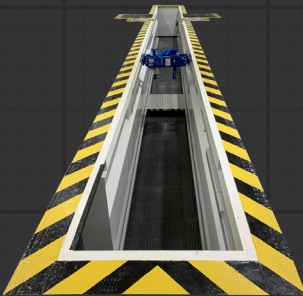

INSPECTION PIT PRE-FABRICATED

- ◆ Pit lengths from 6m-16m
- ◆ Class IV, class VII and rail pits also available
- ◆ Unique bond of steel to concrete
- ◆ Installed by experienced engineers
- ◆ The pit can have built-in brake testing units
- ◆ No height restrictions – headroom not required
- ◆ Non-standard depths and widths available on request



DIAGNOSTIC EQUIPMENT

SMOKE METER DIESEL

- ◆ Accredited to latest Euro 6 standards (to reduce levels of harmful exhaust emissions)
- ◆ Ideal for checking vehicles compliant for low emission zones
- ◆ Will operate down to -15 degrees centigrade in all weathers, with 100 metres range from the workstation
- ◆ Handheld PC tablet included
- ◆ Free training provided by engineer
- ◆ MOT-approved



EMISSIONS ANALYSER PETROL & DIESEL

- ◆ Accredited to latest Euro 6 standards
- ◆ Ideal for checking vehicles compliant for low emission zones
- ◆ Remote operation of up to 100m of unit workstation
- ◆ Colour monitor and solid-state PC (offering the flexibility to run your own programmes)
- ◆ Will operate down to -15 degrees centigrade in all weathers



DIAGNOSTIC EQUIPMENT



HEADLAMP TESTERS

MANUAL & ELECTRONIC

- ◆ Types of headlamps: fog, low & high beam
- ◆ Measurements and values: cutoff, lateral, light intensity and glare
- ◆ Alignment laser
- ◆ Colour touch screen
- ◆ Level compensation for uneven floor
- ◆ Positioning assistance
- ◆ Connectivity: cable & WIFI



WHEEL ALIGNMENT

BLUETOOTH TRANSMISSION

- ◆ Precision bluetooth measuring heads with non-runout fast clamps
- ◆ Reduces test time compared to traditional alignment systems (measurements can be obtained in just 5 minutes)
- ◆ No rolling, pushing or compensation required
- ◆ Can be operated and viewed from tablet or smartphone



CLASS VII MOT BAY

BRAKE TESTER

IN-GROUND

- ◆ Maximum axle load of 6,000kg
- ◆ DVSA-approved
- ◆ GEA-approved
- ◆ Specifically designed for light commercial vehicles
- ◆ Bi-directional rollers



FOUR POST LIFT

LIGHT COMMERCIAL

- ◆ Lifting capacity of 6,500kg
- ◆ 6m platform length
- ◆ Hydraulic lift
- ◆ Two built-in radius plates included
- ◆ Optional hydraulic play detectors



JACKING BEAM

HYDRAULIC

- ◆ Extra wide extending top beam to 1,700mm
- ◆ 260mm lift with proven hydraulics
- ◆ Hose burst vale and pressure relief valve for additional safety
- ◆ Three position mechanical lock
- ◆ Easily operated support arms

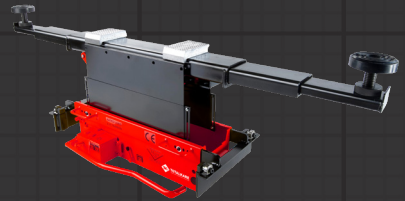

CLASS VII MOT BAY



HEADLAMP TESTER

2500 MODEL

- ◆ DVSA-approved
- ◆ Dual mode: inspection (Roadworthiness, PTI), adjustment
- ◆ Accurate sensor



EMISSIONS ANALYSER

PETROL & DIESEL

- ◆ Accredited to latest Euro 6 standards
- ◆ MOT-approved
- ◆ Measures the efficiency of combustion in your engine

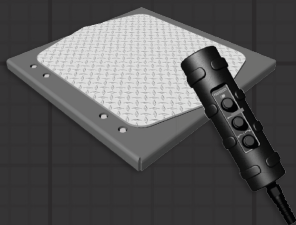

WHEEL PLAY DETECTORS

LIFT POST OR PIT-MOUNTED

- ◆ Combined lateral and rotational vehicle wheel shift from a single compact hydraulic power unit
- ◆ Fast one-man inspection of wheel bearing wear and steering linkage components
- ◆ Auto zero plate centering



IN THE WEB SHOP

Head to www.totalkare.co.uk/shop to view our web shop items

FORKLIFTER SYSTEM

The Totalkare Forklifter ramp system is the perfect piece of equipment to lift your forklift fleet during repairs, maintenance and major component replacement.



LIGHT VEHICLE ADAPTOR

The light vehicle adaptor is expertly designed to allow full access to the vehicle for repairs and maintenance.

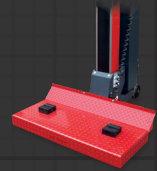

MOBILE ACCESS STEPS

Our access steps are strong and robust, whilst still being relatively lightweight and therefore significantly easy to move around your workshop.



SMALL WHEEL ADAPTORS

Small wheel adaptors enable heavy duty mobile vehicle lifts the ability to lift vehicles with smaller diameter tyres, such as vans and minibuses.



IN THE WEB SHOP

Head to www.totalkare.co.uk/shop to view our web shop items

TRAILER BEAM

The fifth wheel trailer beam is used in conjunction with our heavy duty mobile vehicle lifts to raise trailers for maintenance.

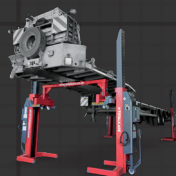

JACKING BEAM

The quiet design of the pump, built into every air jack – significantly enhances performance and reduces noise compared to other jacks on the market, as well as providing unrivalled operational reliability.

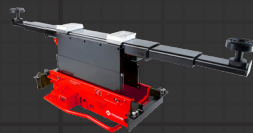

TRANSMISSION JACK

With the gearbox plate utilised, the transmission jack is ideal for use in situations when removing units via the underside of a vehicle is the only option.



BOTTLE JACKS

Small wheel adaptors enable heavy duty mobile vehicle lifts the ability to lift vehicles with smaller diameter tyres, such as vans and minibuses.



IN THE WEB SHOP

Head to www.totalkare.co.uk/shop to view our web shop items

AIR OPERATED PIT JACK

Totalkare's air-operated pit jack is an ideal addition to any commercial vehicle workshop with a vehicle inspection pit, with the air operation offering a safe and efficient method of lifting large vehicles with ease.



HAND OPERATED PIT JACK

The twin-ram operation of the Totalkare pit jack enables operational stability, efficiency and safety. The rams slide horizontally along the pit with ease, ensuring precise positioning beneath the vehicle.



HIGH CAPACITY TROLLEY JACKS

A trolley jack enables you to lift up your vehicle to carry out low level maintenance, such as changing tyres, working on brake assemblies or other tasks which do not necessitate the whole vehicle to be raised.



HIGH LEVEL TROLLEY JACKS

Totalkare's high level trolley jacks provide additional lifting height compared with their high capacity counterparts, though lifting capacity is lessened.



IN THE WEB SHOP

Head to www.totalkare.co.uk/shop to view our web shop items

SUPPORT STANDS

The support stands can be used in two different ways:

- To provide a free wheel support, by removing the mobile vehicle
- As a secondary support where the mobile vehicle lifts are not removed



WHEEL DOLLY

Our wheel dollies can provide easy and safe mounting, demounting and handling of heavy wheels for trucks, buses, coaches and other heavy duty vehicles.



RADIUS PLATES

Vehicle radius plates allow the technician to turn the wheels of a vehicle in a desired direction mechanically, without using the steering wheel inside the vehicle.

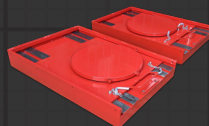

HYDRAULIC PRESS

Our hand and foot operated workshop presses are available from 16kg - 100kg. The press incorporates a fast and safe adjustment of the table height using a braked winch.



TORQUE TOOLS

Head to www.totalkare.co.uk/shop to view our web shop items

PNEUTORQUE PTM TORQUE TOOL

The PneuTorque PTM tools are non-impacting, air driven power tools designed for applying torque to threaded fasteners. The tools use two motors; one to quickly run-down the fastener and the other to achieve final torque.



EVOTORQUE BATTERY TOOL

The EvoTorque battery tool features a brushless motor, data memory and data transfer capabilities to deliver a range of fast, reliable, accurate results. The tool is not constrained by any power cable or hose, improving safety, convenience and versatility.



HANDTORQUE HT3 MULTIPLIER

HandTorque HT3 Multiplier is a precision tool that has been designed with the latest gearbox technology and materials to produce a versatile and extremely compact torque multiplier. Input to the multiplier is via a ratchet torque wrench set to one fifth of the desired output torque.



ADJUSTABLE RATCHET

The adjustable ratchet has been engineered to be compactable, robust and easy to use when handling heavy duty applications. The strong construction gives accurate results to $\pm 4\%$ even in arduous working conditions.



TORQUE TOOLS

Head to www.totalkare.co.uk/shop to view our web shop items

PNEUTORQUE PTS TORQUE TOOL

The PneuTorque PTS tool is a non-impacting, air driven power tool designed for applying torque to threaded fasteners. It contains a single efficient bi-directional air motor producing a very quiet operation, which reduces the need for protection with sound pressure levels from 77 dB(A) to 79 dB(A).



EVOTORQUE2 FASTENER TOOL

EvoTorque2 can apply torque accurately over a wide range of joint rates from hard (high torque rate) through to soft (low torque rate). All of our EvoTorque2 tools are highly tolerant of supply voltage and frequency variation.



ADJUSTABLE SCREWDRIVER KIT

The torque screwdriver is a comfortable and durable tool which provides easy torque adjustment without the need of additional specialist tools. The torque screwdrivers come supplied in kit form with a range of 12 bits, packaged in a high quality hinged box.



RATCHET 'MUSHROOM' HEAD

The professional industrial ratchet with 'mushroom' head, is among the easiest wrenches on the market to accurately set. The square drive features a finger grip on the top ('mushroom' head) that assists with running down the nut until resistance is met.



AIR CONDITIONING

Head to www.totalkare.co.uk/shop to view our web shop items

AIR CON SERVICE UNITS

Our range of air conditioning service units have all it takes to make service work on automotive air conditioners a profitable and safe business.



AIR CON AFTERMARKET OIL

Our range of compressor oils comply with the oils used by automotive manufacturers worldwide for initial fill and for servicing. Always make sure you use the right type (PAG, PAO or POE) with the right viscosity for the air conditioning compressor.



AIR CON DISINFECTION

Refresh-o-mat HD is an ultrasonic atomizer that effectively removes harmful microorganisms from automotive A/C systems. We can also provide a hose set and air conditioner cleaner to be used with the Refresh-o-mat HD.



AIR CON INTERIOR CLEAN-UP

Effective against bacteria, mould, viruses and other microorganisms that can be resistant to certain active substances.



OIL MANAGEMENT

Head to www.totalkare.co.uk/shop to view our web shop items

HOSE REELS

Our range of hose reels come in varying lengths from 10 - 15 metres, and comes as either a single arm, double arm or enclosed hose reel.



MOBILE OIL DISPENSERS

The mobile unit is perfect to dispense viscous lubricants around your workshop. Our models range from 25 - 70 litres, depending on the application suited to your business.



ADBLUE

AdBlue is a liquid used to reduce the nitrous oxide emissions of diesel engines and is made up of a mixture of urea and deionized water that is sprayed into the exhaust system.



WASTE OIL/FLUID DRAINERS

Our low level mobile drainer can be used for the collection of waste oil and used automotive fluids such as antifreeze solutions. Recommended to use when a vehicle hoist/lift or a service pit is not available.



SERVICE & INSPECTION

The purchase of your heavy duty lifting and testing equipment is just the first stage in the journey of becoming a Totalkare customer. With national breakdown and servicing coverage, we are best equipped for all your maintenance requirements throughout the lifespan of your equipment and beyond. We also provide expert advice which is available on the phone 24 hours a day.

Totalkare can offer different service contract options for:

- Mobile Column Lifts
- Fixed Post Lifts
- Brake Testers
- Smoke Meters

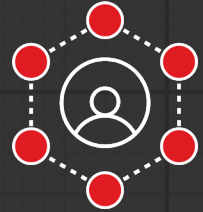

REPORTS OF THOROUGH EXAMINATION

Reports of Thorough Examination are additional to the planned maintenance required by PUWER and should be seen as a complete set of requirements for your heavy duty mobile column lifts in the workshop. To ensure you are fully covered for both PUWER and LOLER regulations, a Report of Thorough Examination can be added to any of our Afterkare packages for lifts.



FINANCE OPTIONS



**LEASE
HIRE**



**LEASE
PURCHASE**



**SHORT TERM
HIRE**



**LOW START
FINANCE**



**ZERO
DEPOSIT**



**OUTRIGHT
PURCHASE**



TRAINING COURSES

MOBILE COLUMN LIFT ONLINE TRAINING

A busy workshop can be a dangerous place if equipment is not operated safely in accordance with manufacturer instructions. While Totalkare builds a number of failsafe measures into its mobile column lifts and ancillary products as standard, it is vital operatives are properly trained to mitigate the risk of personal injury to themselves or others working nearby. Leading the way in workshop safety, Totalkare has created the gold standard in mobile column lift training.

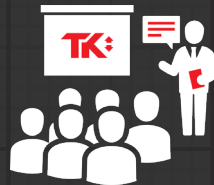

F-GAS CERTIFICATION

We are pleased to be able to offer you in association with the IMI, a cost effective and convenient solution to meet the legal, mandatory requirement.

Our refrigerant handling assessment has the flexibility to be carried out at your premises, using your facilities and equipment.

Advantages are:

- Minimal staff down time
- No travel or accommodation costs
- Minimum disruption
- Minimal workload interference
- Delivery of assessment arranged to suit you

The assessment lasts approximately 1 to 1.5 hours per candidate.

The cost of the Assessment includes:

- An assessor to visit site
- Course learning material
- IMI Registration fees
- IMI Certification fees
- IMI Electronic certificate
- IMI Paper certificate



WORKSHOP EQUIPMENT EXPERTS

WHO ARE TOTALKARE?

With over 40 years' experience within the heavy duty mobile column lift industry, Totalkare offers a comprehensive range of market-leading products and aftersales solutions for heavy duty commercial workshops across all sectors within the UK. A safe and reliable pair of hands, Totalkare provides world class service to multiple industries from its centrally located headquarters in the West Midlands, benefitting from excellent transport links.

SPECIALIST PROVIDERS OF:

| | | | |
|--|--|--|--|
| + Heavy Duty Four & Two Post Lifts | + Light Commercial Four Post Lifts | + Brake Testers | + Online Mobile Column Lift Training |
| + Preventative Maintenance Contracts | + Reports of Thorough Examination | + Workshop Ancillary Equipment | + Mid-life Refurbishment |

CALL 0121 585 2724
EMAIL SALES@TOTALKARE.CO.UK
VISIT WWW.TOTALKARE.CO.UK



TOTALKARE
WORKSHOP EQUIPMENT EXPERTS